

STK E-OCD II Debugger

(E-OCD II Debugger for Starter Kit)

Hardware Manual

Version 1.0.0

Contents

1	Overview	3
1.1	STK E-OCD II Debugger	3
2	How to Use STK E-OCD II Debugger	4
2.1	Description	4
2.2	OCD Interface	5
2.3	Power Selection	6
2.4	Slide Switch for DSCL and DSDA Signals	7
	Revision History	8

List of Figures

Figure 1.	Starter Kit — STK-A94B114-FRN-A	3
Figure 2.	External Interface and User Options.....	4
Figure 3.	OCD Interface (Pin Numbering).....	5
Figure 4.	Power Selection Procedure	6
Figure 5.	Slide Switch (SW4), OCD Interface (J2) on Target Board	7

List of Tables

Table 1.	Pin Assignment for STK E-OCD II Debugger	5
----------	--	---

1 Overview

1.1 STK E-OCD II Debugger

An 8-bit Starter Kit (STK) board supports not only ABOV's 8-bit MCUs but also E-OCD II Debugger board by default. This 8-bit STK has the same features as the general E-OCD II Debugger, and uses the same OCD software.

For this reason, the 8-bit STK board is named as STK E-OCD II Debugger to distinguish from the general E-OCD II Debugger.

In this STK E-OCD II Debugger User Guide, users can learn a method to use hardware of the STK E-OCD II Debugger. For detailed information of hardware and software of the E-OCD II Debugger, please refer to E-OCD II Debugger User Guide that is available at ABOV's website (www.abovsemi.com).

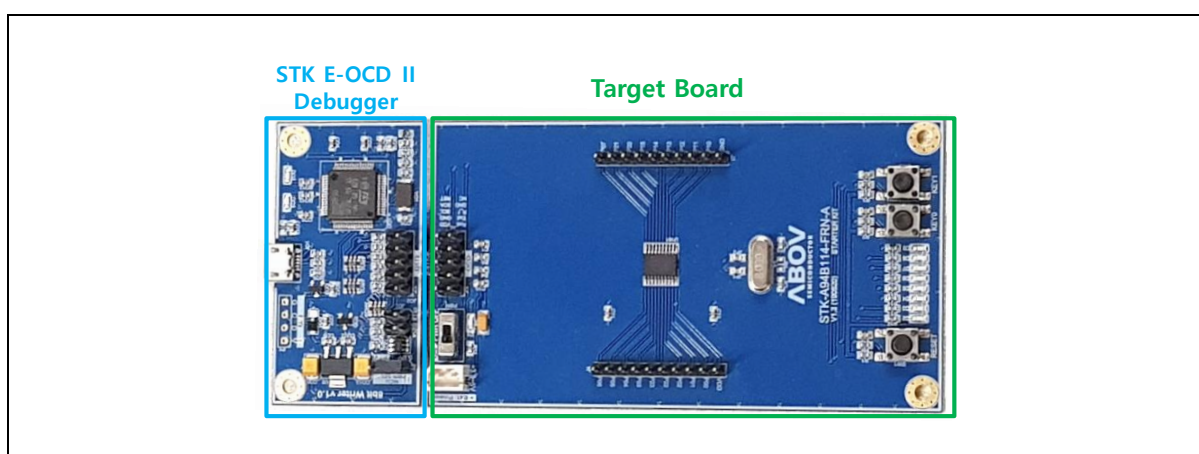

Figure 1. Starter Kit — STK-A94B114-FRN-A

2 How to Use STK E-OCD II Debugger

2.1 Description

Basically, the STK E-OCD II Debugger board supports both USB Connection and OCD Interface that are connecting to a PC and a Target Board respectively.

The STK E-OCD II Debugger board has a jumper (Power Selector) that can select the voltage to meet the requirement of a Target Board. In addition, it has more jumpers supporting UART communication.

Figure 2 shows the external interfaces and user options of the STK E-OCD II Debugger board.

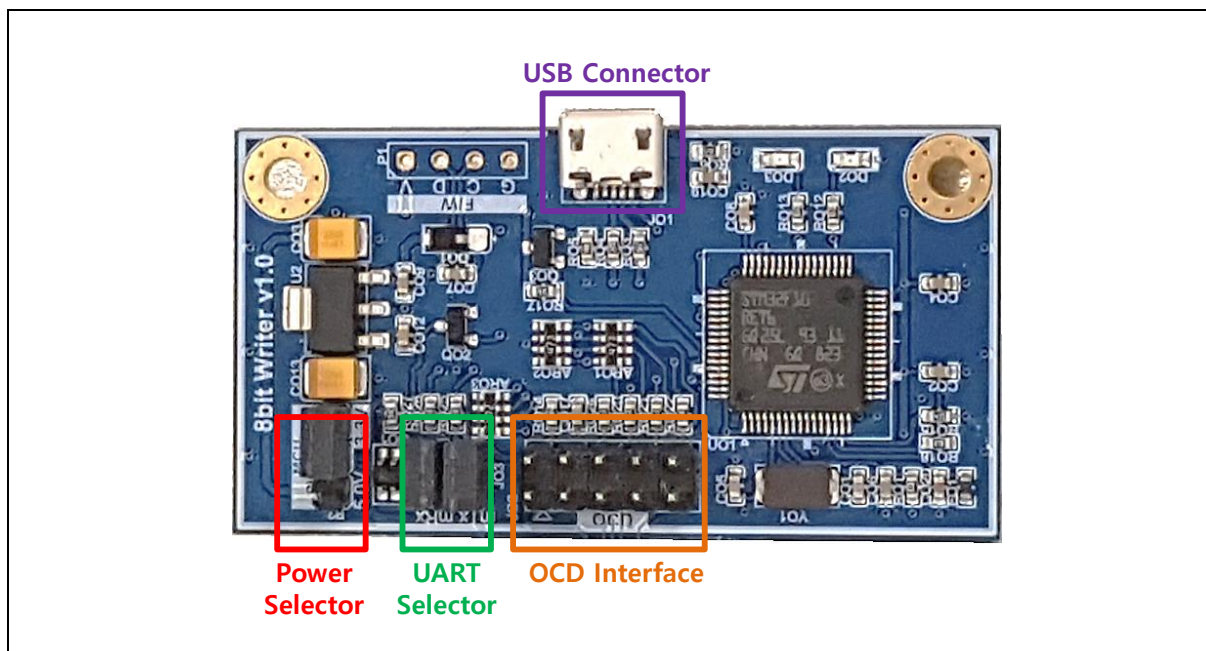

Figure 2. External Interface and User Options

2.2 OCD Interface

OCD Interface consists of pins connecting the STK E–OCD II Debugger board to a Target Board.

As shown in Figure 3 and Table 1, pins #2 VDD, #4 GND, #6 DSCL, and #8 DSDA are used for downloading programs.

#5 RunFlag connects to the RunFlag pin of 94/97 Series Device, while pins #1 PC_TxD and #3 PC_RxD are used for UART communication.

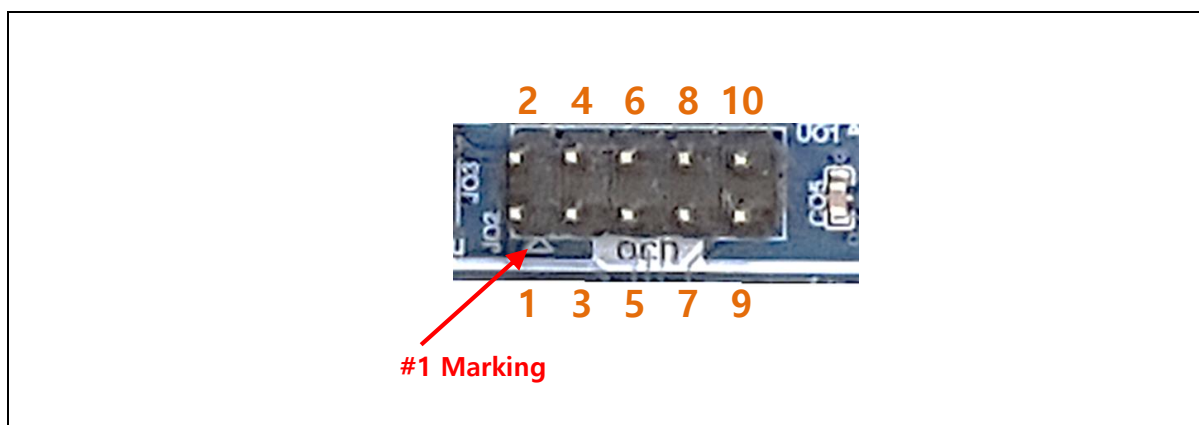

Figure 3. OCD Interface (Pin Numbering)

Table 1. Pin Assignment for STK E–OCD II Debugger

Pin No.	Name	Function
1	PC_TxD	TxD (Transmit Data) to PC–
2	VDD	Detects the target system’s power and interface voltage level.
3	PC_RxD	Rxd (Receive Data) from PC
4	GND	System grounding
5	RunFlag	Connect RunFlag pin of 94/ 97 Series Device.
6	DSCL	Serial clock of the OCD interface.
7	GND	System grounding–
8	DSDA	Serial data of the OCD interface. If the target system’s output is very noisy, it is recommended to add a small capacitance to this line.
9	Not Used	–
10	RESETB (Not Used)	–

2.3 Power Selection

The STK E-OCD II Debugger can select a voltage from +3.3V and +5V using 2-pin Jumper Cap, which is supplied to a Target Board as a power. For this, up to 50mA of Consumption Current Value is allowed for the Target Board. If the Consumption Current exceeds 50mA, users must set the External Power by following the procedure introduced in Figure 4 (Jumper is not used).

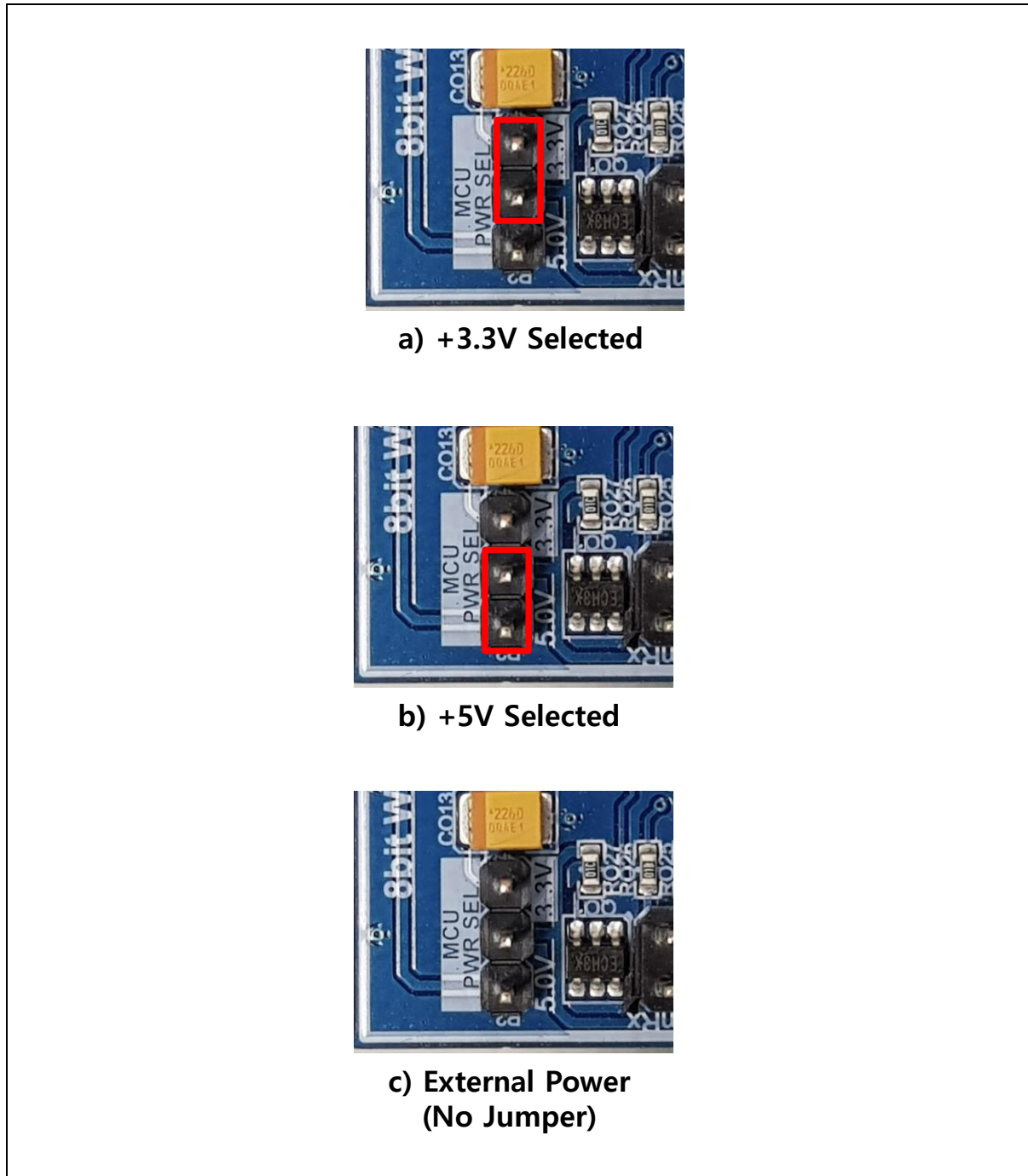

Figure 4. Power Selection Procedure

2.4 Slide Switch for DSCL and DSDA Signals

The Target Board of the STK E-OCD II Debugger has the DSCL and DSDA, the OCD connection signals. They can be connected to or disconnected from the STK E-OCD II Debugger using a Slide Switch as shown in Figure 5.

If users want to connect to the STK E-OCD II Debugger, the users must slide the switch's handle to 'ON' (DSCL, DSDA signal connections).

Figure 5 shows that the OCD Interface Connector (J2) of the Target Board is directly connected to an MCU regardless of the Slide Switch (SW4). That is, the MCU mounted on the Target Board is connected to the STK E-OCD II Debugger through the workflow shown below:

MCU on the Target Board → OCD Interface (J2) Connector →
Slide Switch (SW4) → STK E-OCD II Debugger

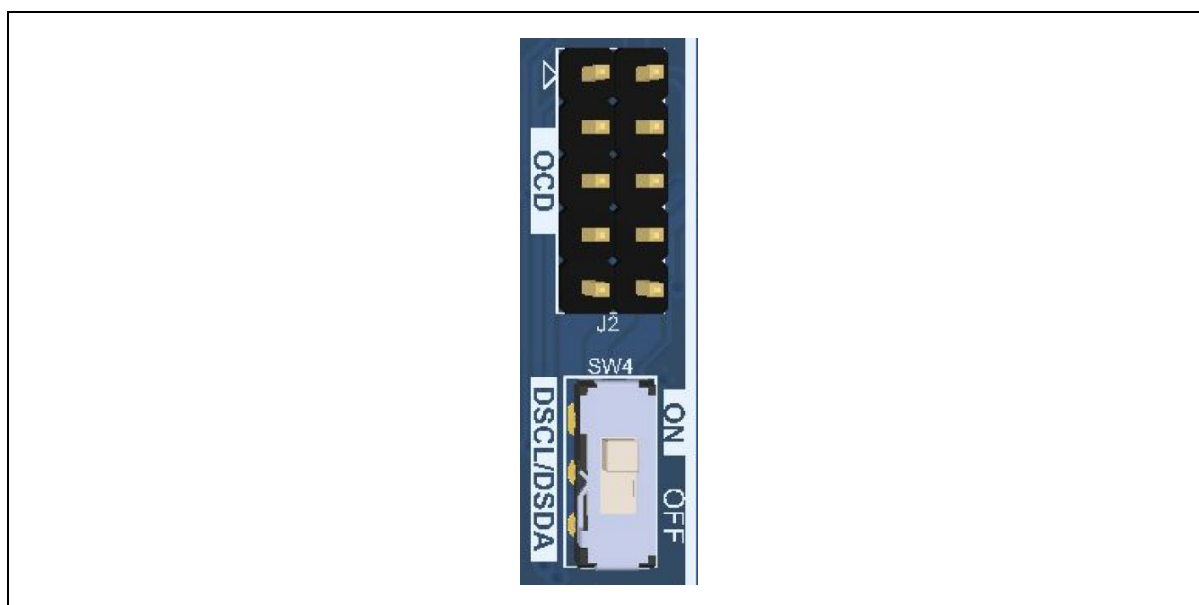

Figure 5. Slide Switch (SW4), OCD Interface (J2) on Target Board

Revision History

Version	Date	Description
1.0.0	Dec. 03, 2020	First released

Korea

Regional Office, Seoul
R&D, Marketing & Sales
8th Fl., 330, Yeongdong-daero,
Gangnam-gu, Seoul,
06177, Korea

Tel: +82-2-2193-2200

Fax: +82-2-508-6903

www.abovsemi.com

Domestic Sales Manager

Tel: +82-2-2193-2206

Fax: +82-2-508-6903

Email: sales_kr@abov.co.kr

HQ, Ochang
R&D, QA, and Test Center
93, Gangni 1-gil, Ochang-eup,
Cheongwon-gun,
Chungcheongbuk-do,
28126, Korea

Tel: +82-43-219-5200

Fax: +82-43-217-3534

www.abovsemi.com

Global Sales Manager

Tel: +82-2-2193-2281

Fax: +82-2-508-6903

Email: sales_gl@abov.co.kr

China Sales Manager

Tel: +86-755-8287-2205

Fax: +86-755-8287-2204

Email: sales_cn@abov.co.kr

ABOV Disclaimer**IMPORTANT NOTICE – PLEASE READ CAREFULLY**

ABOV Semiconductor ("ABOV") reserves the right to make changes, corrections, enhancements, modifications, and improvements to ABOV products and/or to this document at any time without notice. ABOV does not give warranties as to the accuracy or completeness of the information included herein. Purchasers should obtain the latest relevant information of ABOV products before placing orders. Purchasers are entirely responsible for the choice, selection, and use of ABOV products and ABOV assumes no liability for application assistance or the design of purchasers' products. No license, express or implied, to any intellectual property rights is granted by ABOV herein. ABOV disclaims all express and implied warranties and shall not be responsible or liable for any injuries or damages related to use of ABOV products in such unauthorized applications. ABOV and the ABOV logo are trademarks of ABOV. All other product or service names are the property of their respective owners. Information in this document supersedes and replaces the information previously supplied in any former versions of this document.

© 2020 ABOV Semiconductor – All rights reserved